



-  Ambient on request
-  Water heated (WL, WH)
-  Electrically heated (E) on request

Lengths 1, 1.5, 2, 2.5 and 3 metres



## Comfortline Linea B/BB

### Air curtains for doorways with heights up to 4 metres

#### Application

Comfortline Linea air curtains are suitable for larger entrances and doors. With a clean, stylish and clean design it is ideal for both super market entrances and industrial doors. Available for both horizontal and vertical mounting.

#### Comfort

Linea creates an air barrier that efficiently prevents cold draughts and provides a comfortable environment inside the door that makes more floor space available. The large available heating capacity makes the air curtain ideal for keeping the entrance dry and contributing to the heating of the building.

#### Operation and economy

The air inlet grille acts as a filter making the air curtain easy to clean without opening the unit.

#### Design

The wide assortment of lengths makes the Comfortline Linea applicable in openings of all sizes. If the opening is really wide the clean design makes the air curtains fit well next to each other to form a uniform entity over the door.

#### Product specifications

- Timeless and stylish design with concealed screws and rivets.
- Corrosion proof welded housing made of hot zinc-plate steel panels. Painted with two-pack enamel.
- Standard colour RAL 9016. Other RAL-colours optional.
- BMS-control option included. Other controls like IR-Remote and manual-automatic are available as accessory.
- Simple suspension with fixed nuts on the top for mounting with threaded rods.
- The design of the intake air grille makes a separate dust filter superfluous.
- An adjustable outlet grille allows directing the airflow for an optimal air curtain function.

#### Air velocity profile\*1

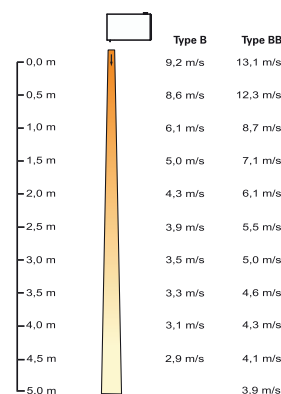

\*1) Mean value across the whole outlet area.

Design and specifications are subject to change without notice.

# Comfortline Linea B/BB

## Technical specifications | Comfortline Linea WL/WH with water heating

Type	Airflow *1 [m³/h]	Sound pressure*2 [dB(A)]	Sound power [dB(A)]	Voltage [V]	Amperage*3 [A]	Power*3 [kW]	Connections dimension*4	Length (L) [mm]	Weight [kg]
B1500WL	5000	45/64	61/80	230V~	4,2	0,980	1"	1500	125
B2000WL	7500	47/66	63/82	230V~	6,3	1,470	1 1/4"	2000	155
B2500WL	10000	48/67	64/83	230V~	8,4	1,960	1 1/4"	2500	200
B3000WL	12500	49/68	65/84	230V~	10,5	2,450	1 1/2"	3000	240
BB1000WL	5000	45/64	61/80	230V~	4,2	0,980	1"	1000	110
BB1500WL	7500	47/66	63/82	230V~	6,3	1,470	1"	1500	145
BB2000WL	10000	48/67	64/83	230V~	8,4	1,960	1 1/4"	2000	180
BB2500WL	12500	49/68	65/84	230V~	10,5	2,450	1 1/4"	2500	225
BB3000WL	15000	50/69	66/85	230V~	12,6	2,940	1 1/2"	3000	265
B1500WH	5000	45/64	61/80	230V~	4,2	0,980	3/4"	1500	125
B2000WH	7500	47/66	63/82	230V~	6,3	1,470	1"	2000	155
B2500WH	10000	48/67	64/83	230V~	8,4	1,960	1 1/4"	2500	200
B3000WH	12500	49/68	65/84	230V~	10,5	2,450	1 1/4"	3000	240
BB1000WH	5000	47/64	63/80	230V~	4,2	0,980	1"	1000	110
BB1500WH	7500	47/66	63/82	230V~	6,3	1,470	3/4"	1500	145
BB2000WH	10000	48/67	64/83	230V~	8,4	1,960	1"	2000	180
BB2500WH	12500	49/68	65/84	230V~	10,5	2,450	1 1/4"	2500	225
BB3000WH	15000	50/69	66/85	230V~	12,6	2,940	1 1/4"	3000	265

\*1) Max airflow, out of 5 steps.

\*2) At lowest/highest airflow. Conditions: Distance to the unit 5 metres. Directional factor:2. Equivalent absorption area: 200 m².

\*3) Rated capacity data.

\*4) Connections are inside thread. DN20 = 3/4" DN25=1"; DN32=1 1/4"; DN40=1 1/2"

Protection class Comfortline Linea water heated: (IP44) splash-proof design.  
CE compliant.

Electrical heating is available on request.

## Dimensions

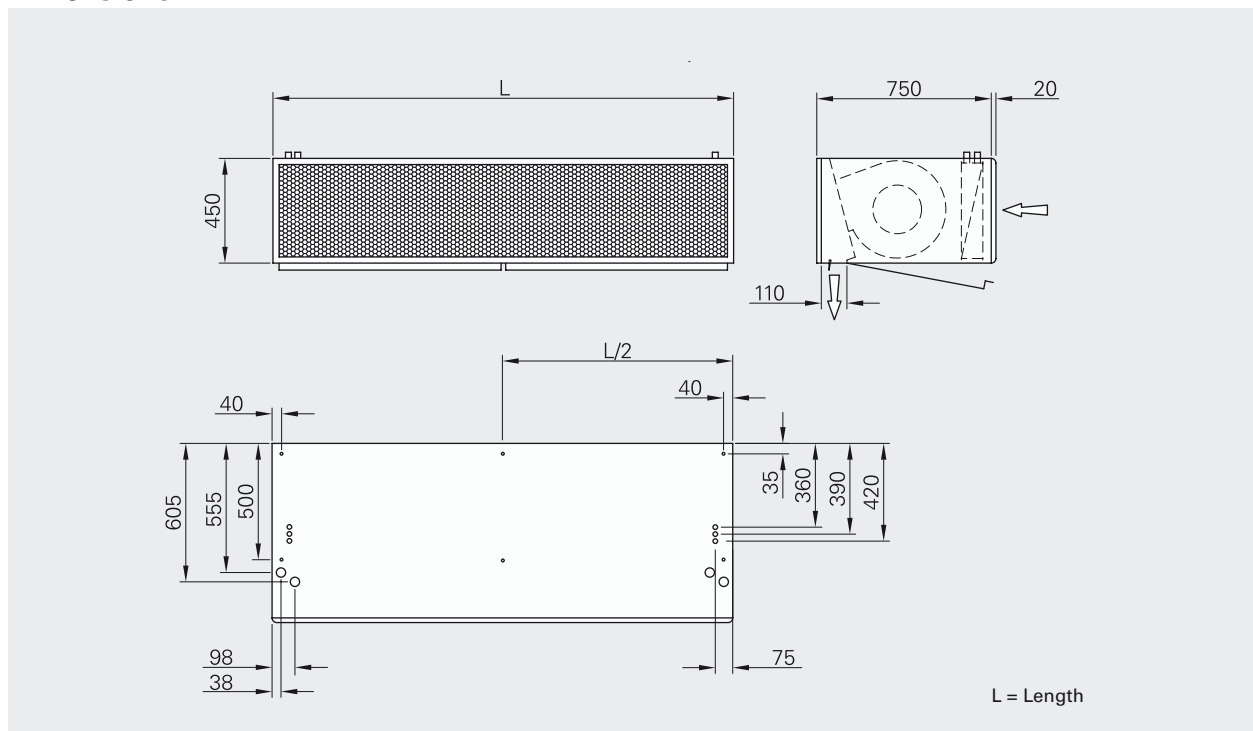

**Other mounting possibilities**

**Vertical mounting**

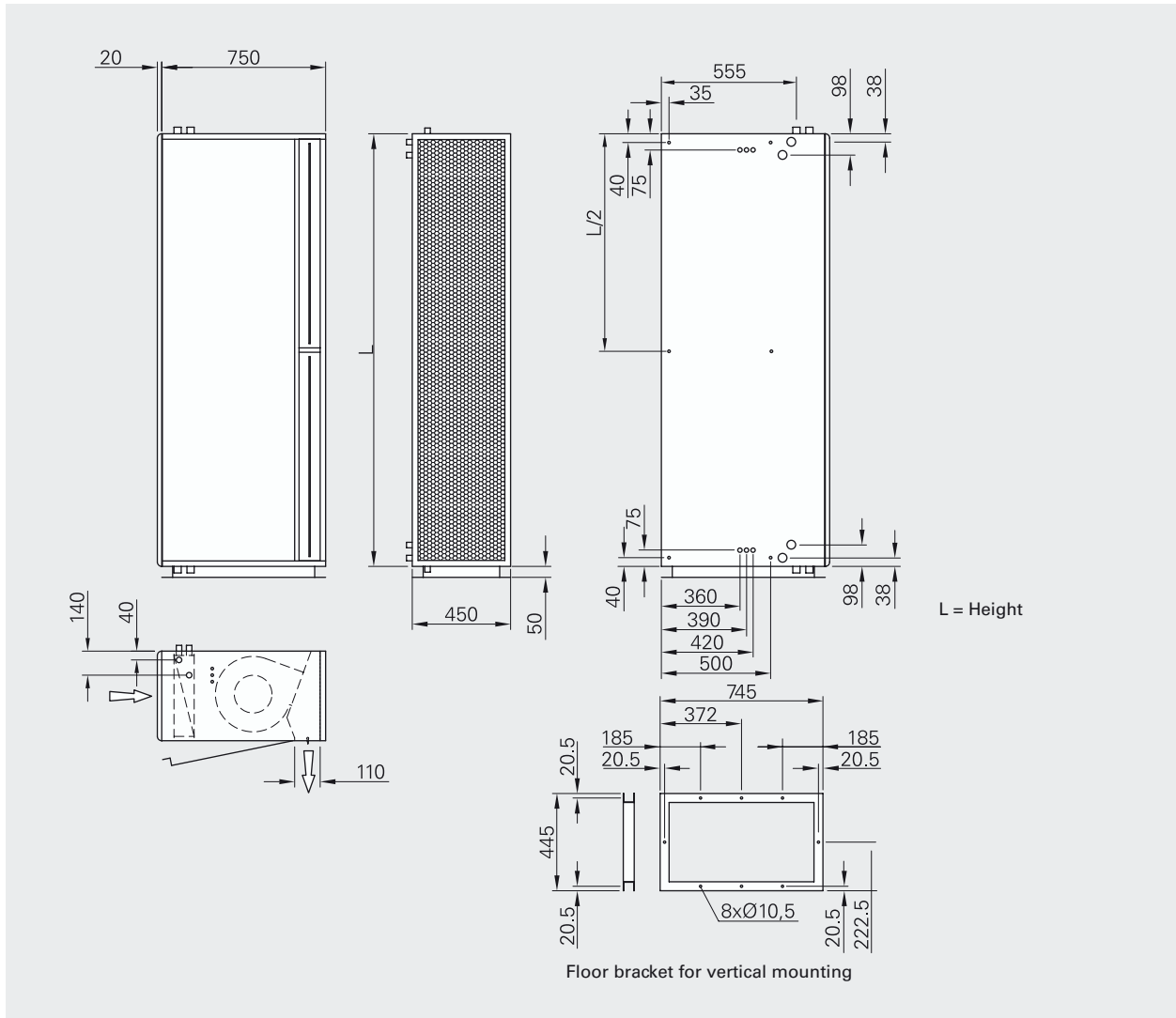

**Recessed mounting**

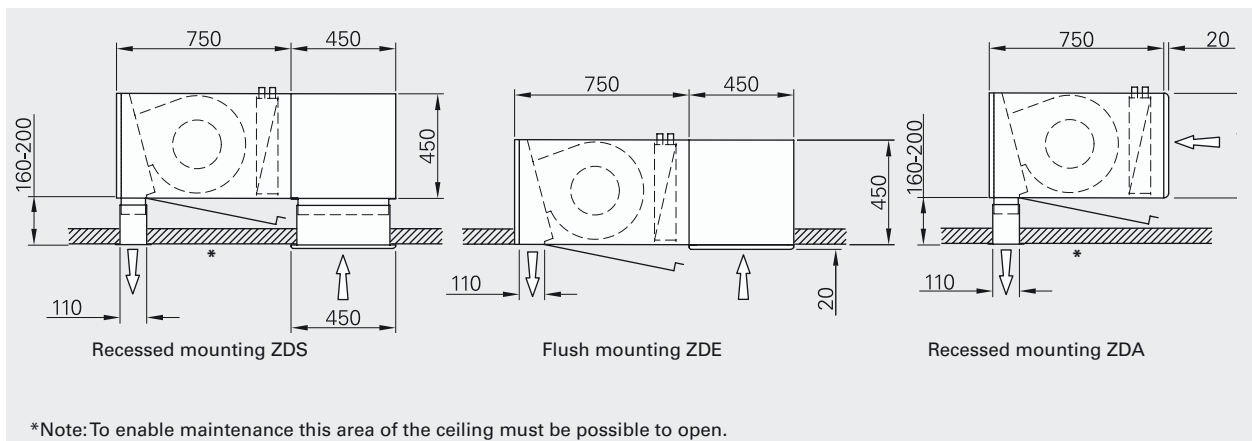

# Comfortline Linea B/BB

## Positioning, mounting and installation

### Positioning

Comfortline Linea is available for horizontal as well as vertical and recessed mounting. Horizontally, the air curtain is positioned hanging visibly above the door. Vertically, it is standing next to the door on either the left or the right side. Recessed, the air curtain is mounted hidden in the ceiling as either ZDS (recessed), ZDE (flush mounted) or ZDA. In all cases the outlet of the air curtain should be positioned as close to the door as possible.

### Mounting

Recessed or horizontal mounting is carried out using M10 threaded rods for ceiling support. Wall brackets for horizontal mounting are available as an accessory. A vertical unit is mounted standing on the accompanying floor bracket that is bolted to the floor and must be secured to a wall or to the ceiling to prevent it from falling over.

### Connection Linea with water heating

The 230V~ supply is connected to the terminals inside the unit. The cable is taken into the unit via the pre-mounted cable glands. The supply should be carried out with a service switch and with fuse according to technical data.

The control panel is delivered with 10 m RJ45 cable. For more connection possibilities please see wiring diagrams.

Heating coil is equipped with inner thread connections, dimension according to technical data table.

## Ordering

### Ordering key

Model name - Performance - Length - Heat medium - Unit shape - Electrical connections position - Water connections position

<b>Model name</b>	Comfortline Linea
<b>Performance</b>	B or BB type performance
<b>Length</b>	1000, 1500, 2000, 2500 or 3000
<b>Heat medium</b>	WL (low temperature water) or WH (high temperature water). Electrical heating and ambient on request.
<b>Unit shape</b>	H (Horizontal), VL (Vertical Left), VR (Vertical Right), ZDS, ZDE or ZDA.
<b>Electrical connections position</b>	1, 2, 3 or 4. See below.
<b>Water connections position</b>	1, 2, 3 or 4. See below.

### Connections position

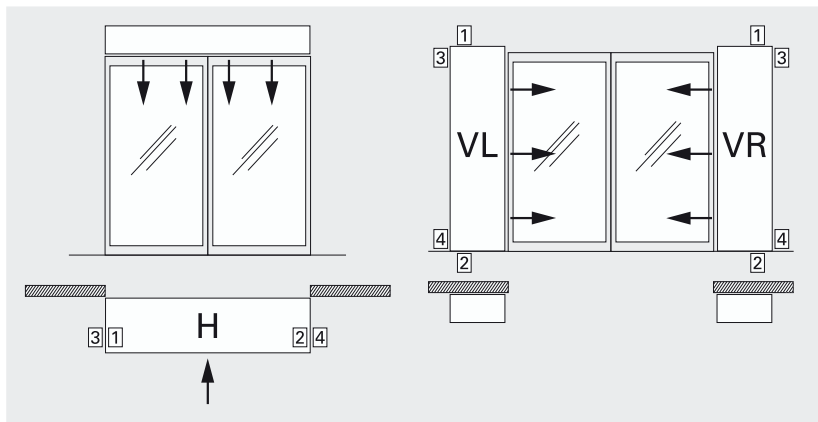

### Ordering example

To order a Comfortline Linea, with BB performance, in 2,5 m length, with low temperature heating coil, recessed mounted type ZDE with connections from the right side (as seen from the inside), the order line should look like this:

Comfortline Linea - BB - 2500 - WL - ZDE - 4 - 4



**Output charts water WH**

		Recommended operation*1			Heating capacity*2			Heating capacity*2		
		Incoming water: 130°C			Incoming air: 15°C			Incoming air: 20°C		
		In / out air temp.: 18/33°C			In / out water temp.: 130/70°C			In / out water temp.: 130/70°C		
Type	Airflow [m³/h]	Output [kW]	Return water [°C]	Water flow [l/s]	Output [kW]	Outgoing air [°C]	Water flow [l/s]	Output [kW]	Outgoing air [°C]	Water flow [l/s]
B1500WH	5000	25,2	35	0,06	47,7	43	0,20	44,5	47	0,18
B2000WH	7500	37,9	33	0,10	79,4	46	0,33	74,0	49	0,31
B2500WH	10000	50,5	34	0,13	103,9	46	0,43	96,8	49	0,40
B3000WH	12500	63,1	33	0,16	129,8	46	0,54	120,9	49	0,50
BB1000WH	5000	25,2	36	0,07	51,3	46	0,21	47,6	48	0,20
BB1500WH	7500	37,9	43	0,11	59,9	39	0,25	55,8	42	0,23
BB2000WH	10000	50,5	37	0,13	98,2	44	0,41	91,5	47	0,38
BB2500WH	12500	63,1	37	0,17	117,7	43	0,49	109,5	46	0,45
BB3000WH	15000	75,7	40	0,21	144,2	44	0,60	133,8	47	0,55

		Recommended operation*1			Heating capacity*2			Heating capacity*2		
		Incoming water: 110°C			Incoming air: 15°C			Incoming air: 20°C		
		In / out air temp.: 18/33°C			In / out water temp.: 110/80°C			In / out water temp.: 110/80°C		
Type	Airflow [m³/h]	Output [kW]	Return water [°C]	Water flow [l/s]	Output [kW]	Outgoing air [°C]	Water flow [l/s]	Output [kW]	Outgoing air [°C]	Water flow [l/s]
B1500WH	5000	25,2	35	0,06	48,4	44	0,40	45,3	47	0,37
B2000WH	7500	37,9	33	0,10	81,6	47	0,67	76,0	50	0,63
B2500WH	10000	50,5	34	0,13	106,6	47	0,88	99,6	50	0,82
B3000WH	12500	63,1	33	0,16	132,8	47	1,09	124,1	50	1,02
BB1000WH	5000	25,2	36	0,07	53,8	47	0,44	50,1	50	0,41
BB1500WH	7500	37,9	43	0,11	61,0	39	0,50	57,0	43	0,47
BB2000WH	10000	50,5	37	0,13	100,4	45	0,83	93,8	48	0,78
BB2500WH	12500	63,1	37	0,17	121,5	44	1,00	113,5	47	0,94
BB3000WH	15000	75,7	40	0,21	147,7	44	1,22	138,1	47	1,14

		Recommended operation*1			Heating capacity*2			Heating capacity*2		
		Incoming water: 90°C			Incoming air: 15°C			Incoming air: 20°C		
		In / out air temp.: 18/33°C			In / out water temp.: 90/70°C			In / out water temp.: 90/70°C		
Type	Airflow [m³/h]	Output [kW]	Return water [°C]	Water flow [l/s]	Output [kW]	Outgoing air [°C]	Water flow [l/s]	Output [kW]	Outgoing air [°C]	Water flow [l/s]
B1500WH	5000	25,2	45	0,14	39,7	39	0,49	36,5	42	0,45
B2000WH	7500	37,9	41	0,19	66,9	42	0,82	61,5	44	0,76
B2500WH	10000	50,5	42	0,26	87,7	41	1,08	80,7	44	0,99
B3000WH	12500	63,1	42	0,32	109,2	41	1,34	100,5	44	1,23
BB1000WH	5000	25,2	44	0,13	44,4	41	0,54	40,8	44	0,50
BB1500WH	7500	37,9	54	0,26	50,0	35	0,61	45,8	38	0,56
BB2000WH	10000	50,5	46	0,28	82,3	39	1,01	75,7	43	0,93
BB2500WH	12500	63,1	46	0,35	99,7	39	1,23	91,7	42	1,13
BB3000WH	15000	75,7	50	0,46	121,1	39	1,49	111,4	42	1,37

\*1) To save energy and create good comfort in openings not exposed to unusual loads.

\*2) For heating capacity at others speeds than full the conversion table to the right can be used. ΔT is the temperature difference between incoming and outgoing air.

Fan position	Airflow	Output	ΔT	Water flow
Max (5/5)	100%	1	1	1
Mid (3/5)	75%	0,842	1,133	0,842
Min (1/5)	50%	0,651	1,315	0,651

Heating coil max water temperature 120 °C and max pressure 16 bar. For inlet temperature 130 °C the return temperature must be kept below 70 °C. Mean water temperature must not exceed 100 °C.

**Output charts water WH**

Type	Recommended operation*1				Heating capacity*2			Heating capacity*2		
	Incoming water: 80°C				Incoming air: 15°C			Incoming air: 20°C		
	In / out air temp.: 18/33°C				In / out water temp.: 80/60°C			In / out water temp.: 80/60°C		
	Airflow [m³/h]	Output [kW]	Return water [°C]	Water flow [l/s]	Output [kW]	Outgoing air [°C]	Water flow [l/s]	Output [kW]	Outgoing air [°C]	Water flow [l/s]
B1500WH	5000	25,2	48	0,19	33,0	35	0,40	29,9	38	0,37
B2000WH	7500	37,9	44	0,25	5,6	37	0,68	50,0	40	0,61
B2500WH	10000	50,5	45	0,35	72,6	37	0,89	65,6	40	0,80
B3000WH	12500	63,1	44	0,43	90,5	37	1,11	81,7	40	1,00
BB1000WH	5000	25,2	46	0,18	36,5	37	0,45	32,9	40	0,40
BB1500WH	7500	37,9	58	0,43	41,6	32	0,51	37,6	35	0,46
BB2000WH	10000	50,5	49	0,40	68,5	35	0,84	61,9	38	0,76
BB2500WH	12500	63,1	49	0,49	82,8	35	1,01	74,7	38	0,91
BB3000WH	15000	75,7	53	0,69	100,7	35	1,23	91,0	38	1,11

\*1) To save energy and create good comfort in openings not exposed to unusual loads.

\*2) For heating capacity at others speeds than full the conversion table to the right can be used.  $\Delta T$  is the temperature difference between incoming and outgoing air.

Fan position	Airflow	Output	$\Delta T$	Water flow
Max (5/5)	100%	1	1	1
Mid (3/5)	75%	0,842	1,133	0,842
Min (1/5)	50%	0,651	1,315	0,651

Heating coil max water temperature 120 °C and max pressure 16 bar. For inlet temperature 130 °C the return temperature must be kept below 70 °C. Mean water temperature must not exceed 100 °C.

Output charts water WL

Type	Airflow [m³/h]	Recommended operation*1			Heating capacity*2			Heating capacity*2		
		Output [kW]	Return water [°C]	Water flow [l/s]	Output [kW]	Outgoing air [°C]	Water flow [l/s]	Output [kW]	Outgoing air [°C]	Water flow [l/s]
B1500WL	5000	25,2	36	0,14	46,0	42	0,56	41,5	45	0,51
B2000WL	7500	37,9	31	0,19	74,9	45	0,92	67,9	47	0,83
B2500WL	10000	50,5	32	0,25	96,5	44	1,18	87,5	46	1,07
B3000WL	12500	63,1	33	0,33	118,7	43	1,45	107,1	46	1,31
BB1000WL	5000	25,2	34	0,13	48,4	44	0,59	43,7	46	0,53
BB1500WL	7500	37,9	42	0,24	59,0	38	0,72	53,2	41	0,65
BB2000WL	10000	50,5	35	0,27	90	42	1,10	81,5	44	1,00
BB2500WL	12500	63,1	35	0,34	110,9	41	1,36	100,5	44	1,23
BB3000WL	15000	75,7	35	0,41	132,9	41	1,63	120,3	44	1,47

Type	Airflow [m³/h]	Recommended operation*1			Heating capacity*2			Heating capacity*2		
		Output [kW]	Return water [°C]	Water flow [l/s]	Output [kW]	Outgoing air [°C]	Water flow [l/s]	Output [kW]	Outgoing air [°C]	Water flow [l/s]
B1500WL	5000	25,2	39	0,19	29,3	32	0,24	24,6	35	0,20
B2000WL	7500	37,9	34	0,25	49,7	35	0,40	42,4	37	0,34
B2500WL	10000	50,5	35	0,35	64,3	34	0,52	54,9	36	0,44
B3000WL	12500	63,1	36	0,45	78,3	34	0,63	66,4	36	0,54
BB1000WL	5000	25,2	37	0,18	30,9	33	0,25	26,1	36	0,21
BB1500WL	7500	37,9	36	0,27	37,2	30	0,30	31,2	32	0,25
BB2000WL	10000	50,5	38	0,38	59,4	33	0,48	50,5	35	0,41
BB2500WL	12500	63,1	38	0,48	73,7	33	0,60	62,8	35	0,51
BB3000WL	15000	75,7	39	0,59	87,4	32	0,71	74,3	35	0,60

Type	Airflow [m³/h]	Recommended operation*1			Heating capacity*2			Heating capacity*2		
		Output [kW]	Return water [°C]	Water flow [l/s]	Output [kW]	Outgoing air [°C]	Water flow [l/s]	Output [kW]	Outgoing air [°C]	Water flow [l/s]
B1500WL	5000	25,2	41	0,33	27,1	31	0,33	22,5	33	0,27
B2000WL	7500	37,9	37	0,40	45,3	33	0,55	38,1	35	0,46
B2500WL	10000	50,5	38	0,56	58,5	32	0,71	49,1	35	0,59
B3000WL	12500	63,1	39	0,74	71,5	32	0,87	59,8	34	0,73
BB1000WL	5000	25,2	40	0,30	28,5	29	0,34	23,8	34	0,29
BB1500WL	7500	37,9	48	0,74	34,5	31	0,42	28,6	31	0,35
BB2000WL	10000	50,5	41	0,66	54,3	31	0,66	45,6	34	0,55
BB2500WL	12500	63,1	40	0,75	67,1	31	0,81	56,5	33	0,68
BB3000WL	15000	75,7	42	1,03	79,9	31	0,97	67,1	33	0,81

\*1) To save energy and create good comfort in openings not exposed to unusual loads.

\*2) For heating capacity at others speeds than full the conversion table to the right can be used. ΔT is the temperature difference between incoming and outgoing air.

Fan position	Airflow	Output	ΔT	Water flow
Max (5/5)	100%	1	1	1
Mid (3/5)	75%	0,842	1,133	0,842
Min (1/5)	50%	0,651	1,315	0,651

Heating coil max water temperature 120 °C and max pressure 16 bar. For inlet temperature 130 °C the return temperature must be kept below 70 °C. Mean water temperature must not exceed 100 °C.

**Output charts water WL**

Type	Airflow [m <sup>3</sup> /h]	Recommended operation*1			Heating capacity*2			Heating capacity*2		
		Output	Return water	Water flow	Output	Outgoing air	Water flow	Output	Outgoing air	Water flow
		[kW]	[°C]	[l/s]	[kW]	[°C]	[l/s]	[kW]	[°C]	[l/s]
		Incoming water: 55°C			Incoming air: 15°C			Incoming air: 20°C		
		In / out air temp.: 18/33°C			In / out water temp.: 55/35°C			In / out water temp.: 55/35°C		
<b>B1500WL</b>	5000	25,2	43	0,51	22,3	28	0,27	17,7	31	0,21
<b>B2000WL</b>	7500	37,9	39	0,59	37,9	30	0,46	30,4	32	0,37
<b>B2500WL</b>	10000	48,8	39	0,75	48,8	30	0,59	39,4	32	0,48
<b>B3000WL</b>	12500	63,1	42	1,13	59,4	29	0,72	47,9	31	0,58
<b>BB1000WL</b>	5000	25,2	41	0,44	23,6	29	0,29	18,7	31	0,23
<b>BB1500WL</b>	7500	37,9	44	0,83	28,3	26	0,34	22,4	29	0,27
<b>BB2000WL</b>	10000	50,5	41	0,80	45,3	28	0,55	36,3	31	0,44
<b>BB2500WL</b>	12500	52,6	37	0,71	56,1	28	0,68	45,1	31	0,54
<b>BB3000WL</b>	15000	65,6	39	0,98	66,6	28	0,81	53,4	31	0,64

\*1) To save energy and create good comfort in openings not exposed to unusual loads.

\*2) For heating capacity at others speeds than full the conversion table to the right can be used.  $\Delta T$  is the temperature difference between incoming and outgoing air.

Fan position	Airflow	Output	$\Delta T$	Water flow
<b>Max (5/5)</b>	100%	1	1	1
<b>Mid (3/5)</b>	75%	0,842	1,133	0,842
<b>Min (1/5)</b>	50%	0,651	1,315	0,651

Heating coil max water temperature 120 °C and max pressure 16 bar. For inlet temperature 130 °C the return temperature must be kept below 70 °C. Mean water temperature must not exceed 100 °C.

# Comfortline Linea B/BB

## Pressure drop water

Water pressure drop over Linea WH water coils type B

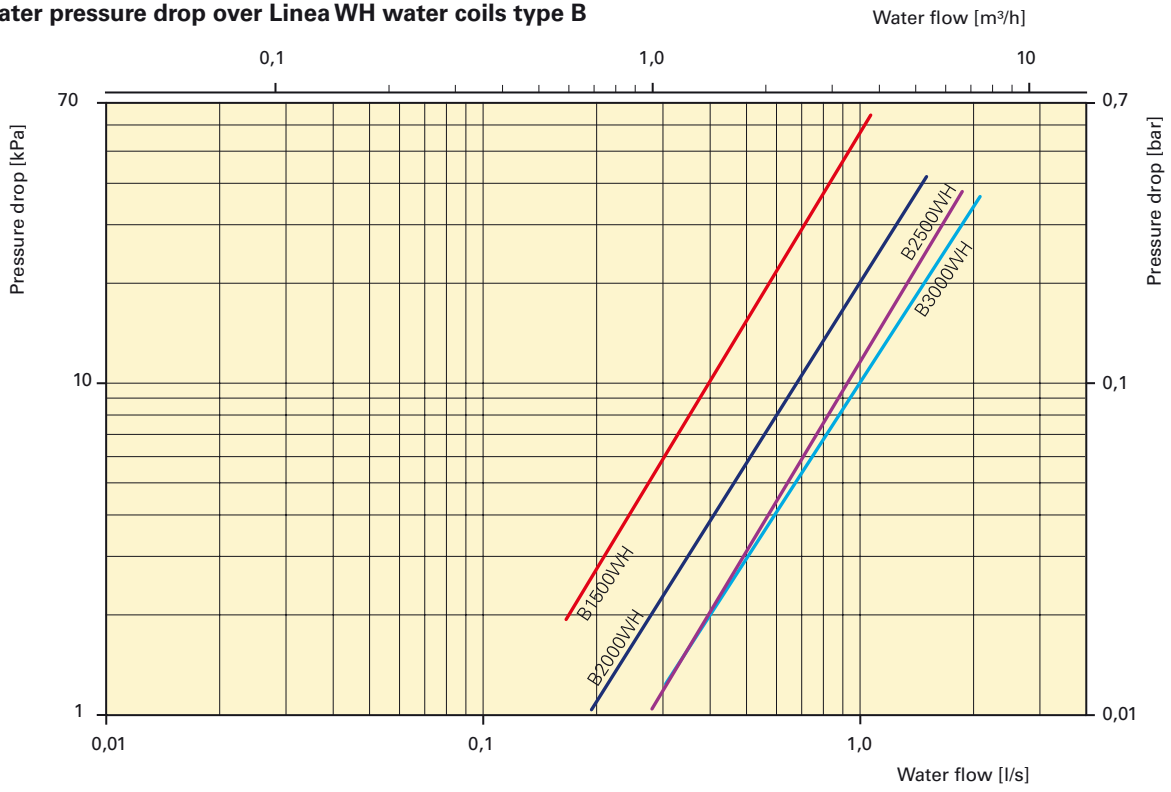

## Pressure drop water

Water pressure drop over Linea WH water coils type BB

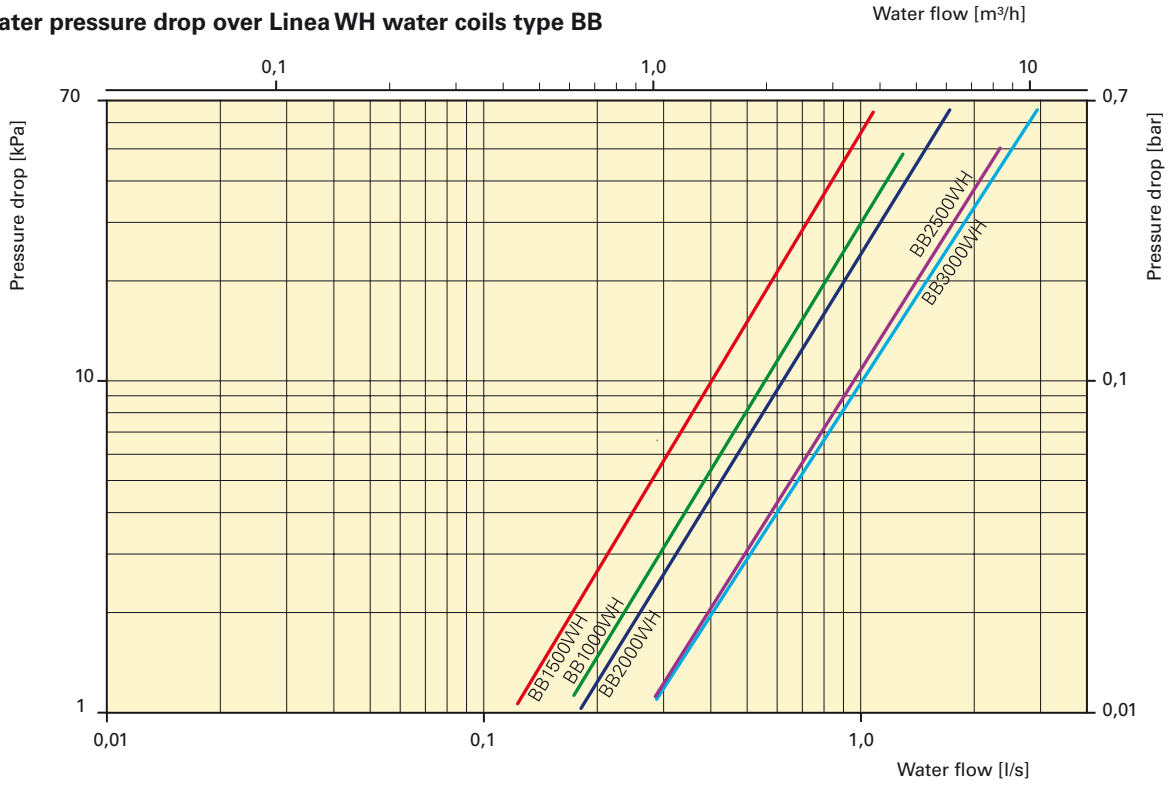

**Pressure drop water**

**Water pressure drop over Linea WL water coils type B**

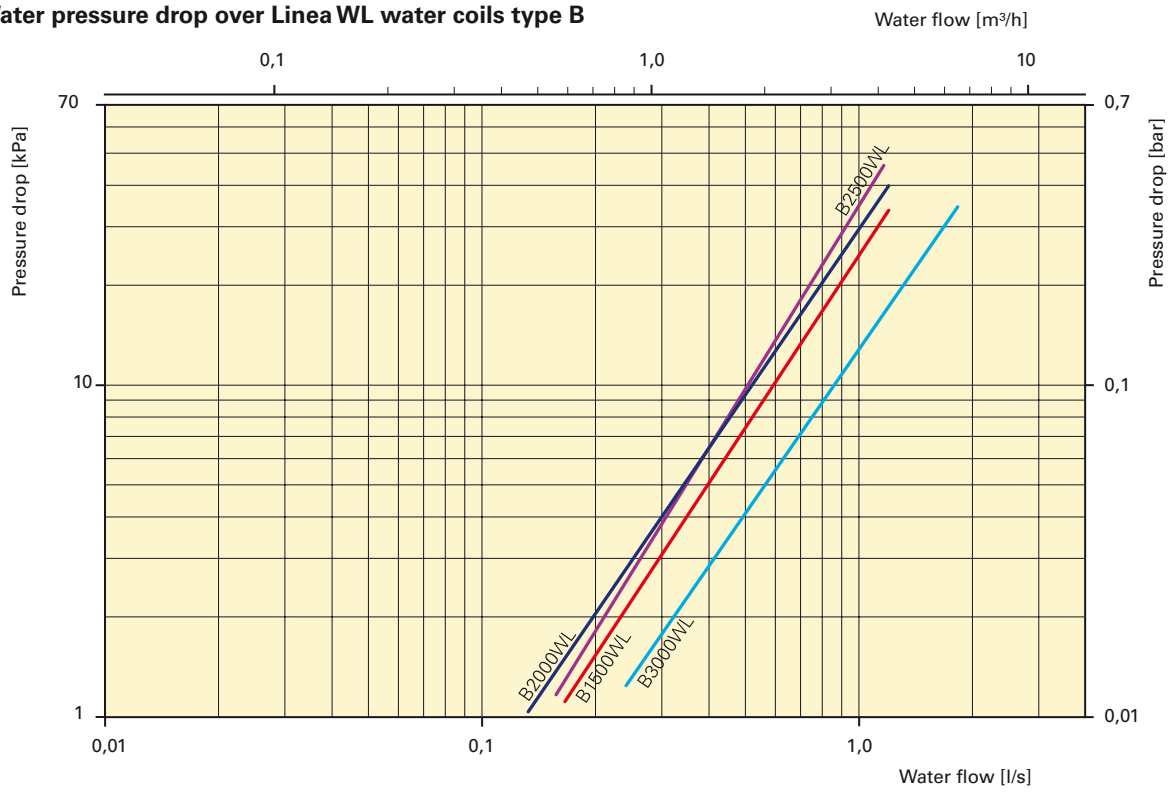

**Water pressure drop over Linea WL water coils type BB**

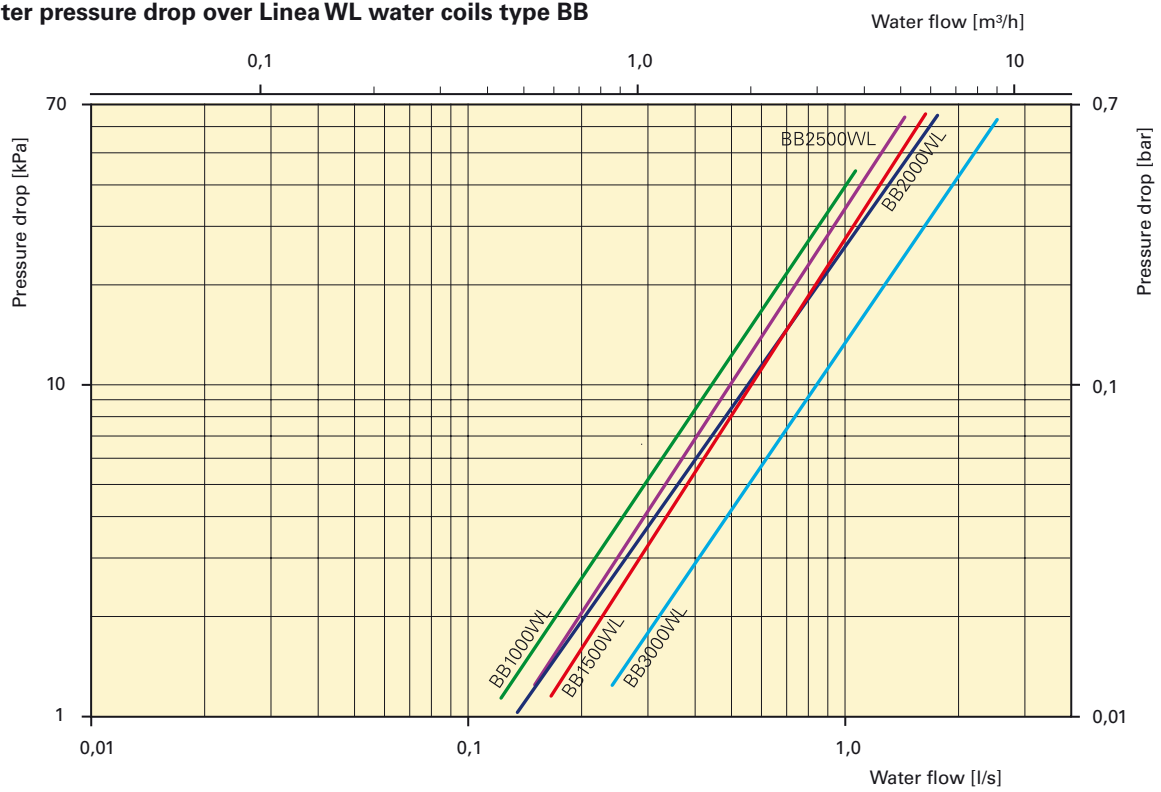

**Pressure drop water**

**Water pressure drop over regulation and valves**

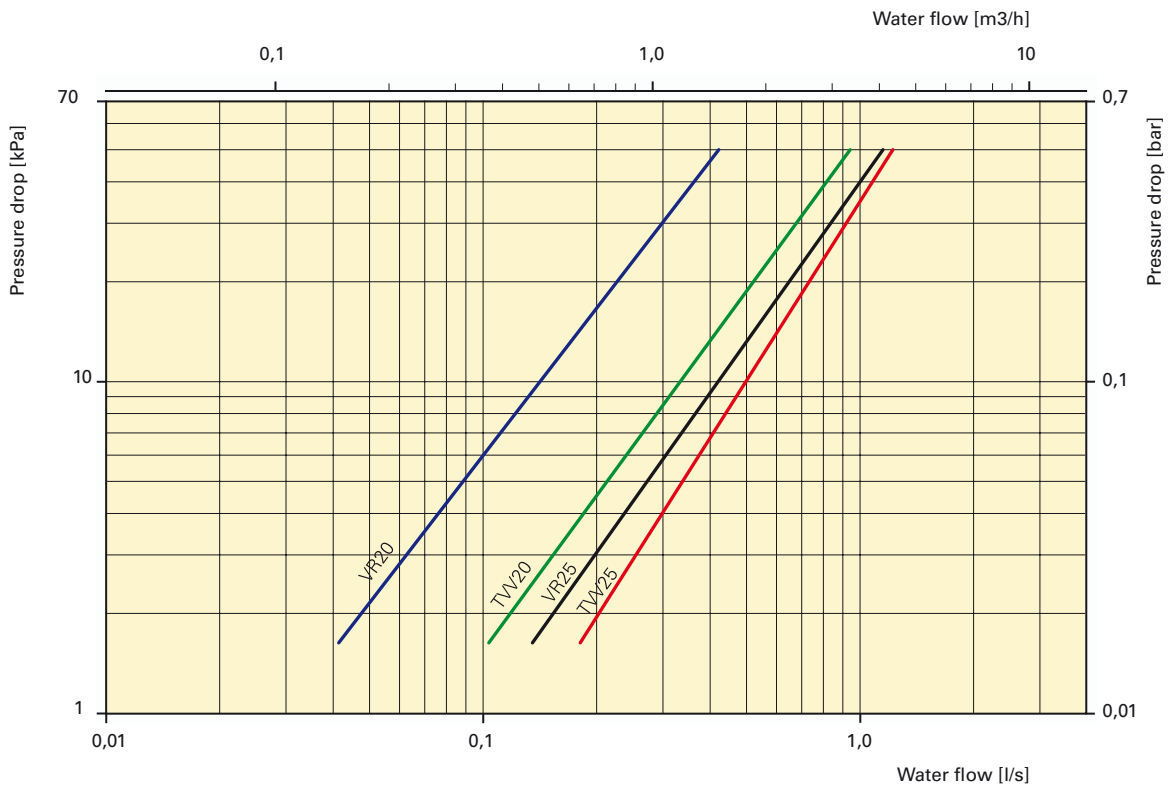
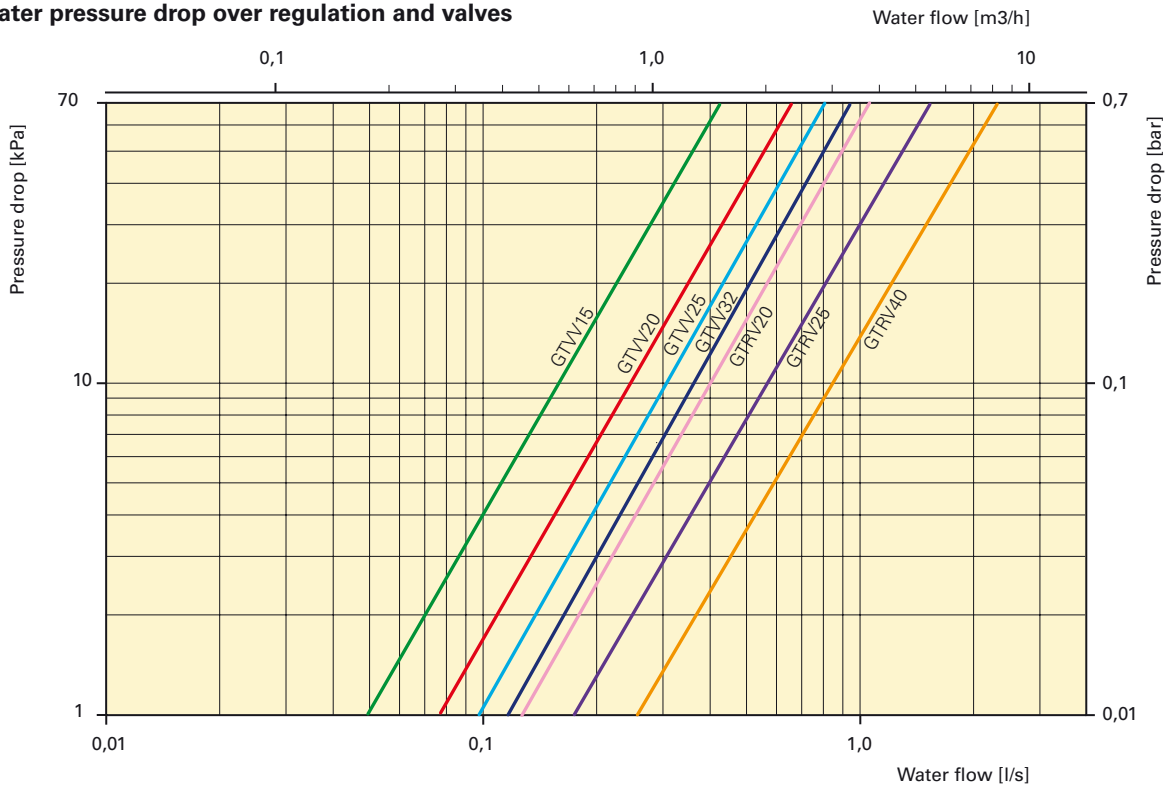

The pressure drop is calculated for an average temperature of 70°C (PWW 80/60).  
 For other water temperatures, the pressure drop is multiplied by the factor K.

Average temp. water °C	40	50	60	70	80	90
K	1,10	1,06	1,03	1,00	0,97	0,93

## Complete control kits

### Water

#### Standard control

With the standard control panel D705IR the fan speed is selected in five steps. With the summer/winter switch the heating is turned on/off. The control panel is configured for dual functionality which is switched with an external contact, i.e. a door contact or a room thermostat, that may be connected to the control panel.

With a DIP-switch inside the control panel it is decided whether the external contact switches the air curtain on/off (Position ON) or if it switches between high and low speed (Position OFF). High speed is chosen freely among the five fan speeds available. The high speed is set on the controller when the contact is open.

To save the motors of the air curtain an over-run time between 15 and 75 seconds can be set on the controller. Up to 12 units can be controlled simultaneously.

#### BMS control

The water heated air curtain is prepared for BMS-control via the 0-10V terminals on the internal PC-board. The valve must then be controlled via an external room thermostat.

## Wiring diagrams Comfortline Linea B/BB W

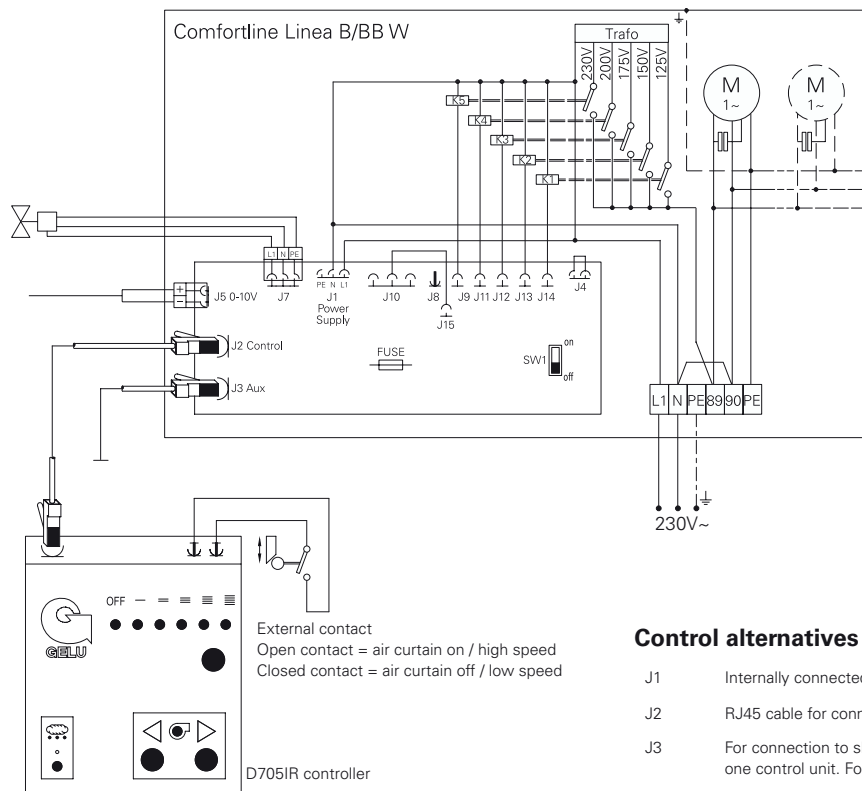

### Control alternatives water heating

- J1 Internally connected.
- J2 RJ45 cable for connection to controller.
- J3 For connection to slave unit. Up to 12 units can be connected to one control unit. For 0-10 V control use J5 on all units.
- J4 Remove bridge for start/stop through BMS system. Open contact = off.
- J5 0-10 V control via BMS system. See SW1.
- J7 Magnetic valve connection. Activated by summer/winter switch on control unit.
- SW1 For 0-10 V BMS control put switch in position ON. For normal function set switch in position OFF.
- External contact Connect external contact to terminals in controller for on/off function.

0-10 V Input signal (for BMS control)

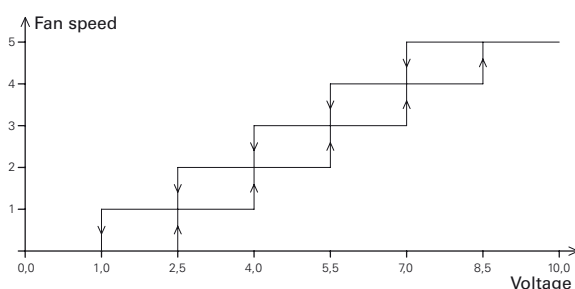

For more information regarding control alternatives please contact Frico.

## Accessories

### Controllers

D705IR	Standard controller for water heated and ambient air curtains (included in delivery).
IR01	Infrared remote controller for use with D705IR.
D715M	Programmable manual/automatic controller for water heated units. Enables control with room thermostat and door contact.

### Door contacts

GLS	Mechanical position limit switch.
MDC	Magnetic door contact with 3 alternating contacts and time delay function.

### Thermostats

TBK10	Mechanical bimetal thermostat with gas-filled membrane. Alternating contact. External dial.
T10	Electronic thermostat. Internal dial. Max 10 A.
TK10	Electronic thermostat. External dial. Max 10 A.
TKS16	Electronic thermostat. Alternating contact. External dial. Max 16 A.

### Valves and water regulations

VR20	Valve set containing AV20 stop valve, JVF20 adjustment valve, TRV20 3-way valve, SD20 electronic actuator and BPV10 by-pass valve.
VR25	Valve set containing AV25 stop valve, JVF25 adjustment valve, TRV25 3-way valve, SD20 electronic actuator and BPV10 by-pass valve.
SD10	Electrothermal actuator for summer/winter function. For use with GTVV and GTRV valves.
SD20	Electronic on/off actuator. For use with TVV-valves.
GCT02	Temperature controller for constant outblow temperature control. For use with GTVV and GTRV valves. 2 m capillary.
GTVV20	2-way valve DN20 (3/4").
GTVV25	2-way valve DN25 (1").
GTVV32	2-way valve DN32 (1 1/4").
TVV20	2-way valve DN20 (3/4").
TVV25	2-way valve DN25 (1").

GTRV20	3-way mixing valve DN20 (3/4"). Incl. threaded nozzles (3 pcs).
GTRV25	3-way mixing valve DN25 (1"). Incl. threaded nozzles (3 pcs).
GTRV40	3-way mixing valve DN40 (1 1/2"). Incl. threaded nozzles DN32 (3 pcs) and DN40 (3 pcs).
GMV20	2-way magnetic valve DN20 (3/4").
GMV25	2-way magnetic valve DN25 (1").
AFT06	Anti-freeze thermostat with 6 m capillary for mounting on the heating coil.
FH0820	Flexible hose DN20, length 0,8 m.
FH0525	Flexible hose DN25, length 0,5 m.
FH1025	Flexible hose DN25, length 1 m.

### Cables

GMC10	10 m RJ45 cable for connection of D705IR.
GMC20	20 m RJ45 cable for connection of D705IR.
GMC30	30 m RJ45 cable for connection of D705IR.
GMC40	40 m RJ45 cable for connection of D705IR.

### Mounting kits

GWB640	Wall bracket 640 mm. For B/BB size units.
GP1010	Threaded bars 1000 mm. Size M10. Set of 2 pcs.
GP1010S	Threaded bars 1000 mm with vibration damper. Size M10. Set of 2 pcs.
GCP	Covers for threaded bars. Set of 2 pcs.
GCSB	Square shape cover for suspension, cables and pipes. For Linea B/BB.

### Selecting mounting kits:

Unit length	No of mounting kits needed per air curtain
1000 mm	2
1500 mm	2
2000 mm	3
2500 mm	3
3000 mm	4



**Frico GmbH**

*A Frico Group Company*

Dieselstraße 4 · 73278 Schlierbach  
Tel.: (07021) 97003-0, Fax: (07021) 76841  
info@gelu-frico.de · www.gelu-frico.com

**Frico AB**

Box 102, SE-433 22 Partille  
Sverige  
Tel. 031 336 86 00  
Fax. 031 26 28 25  
mailbox@frico.se · www.frico.se